

Instruction Manual

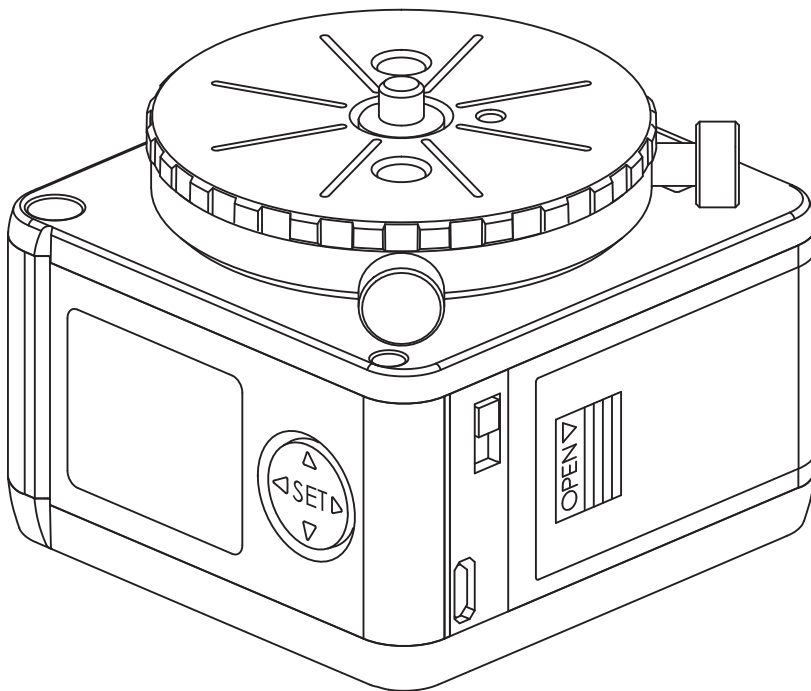

Instruction manual and additional information
Bedienungsanleitung und weitere Informationen
Manuel d'instruction et informations complémentaires
Manual de instrucciones e información adicional
Handleiding en aanvullende informatie
www.bresser.de/P4964130

Safety Precautions

To ensure your safety, please read the following instructions carefully before use.
To prevent bodily injuries or property damage, this instruction provides important safety information.



Caution!

Incorrect handling may cause injury to body or property.

⚠ Max. Load Capacity:

at Astronomical Mode : 5kg (C.O.G. height of 10cm from the turntable / less than 20kg • cm of moment load)

at Time-Lapse Mode

When the turntable and the ground are close to parallel: 5 kg

When the turntable and the ground are close to perpendicular: 2 kg
(2kg at C.O.G. height of 10cm from the turntable / less than 20kg • cm of moment load) use under above mentioned figures

Depending on the position of the image equipment the C.O.G. even below the above mass, there are some configurations that are difficult to balance due to its shooting angle or total balance.

- ⚠ Remove camera and other equipment from the unit while transporting.
Camera or other equipment may fall from the unit and cause bodily injury or property damage.
- ⚠ To prevent injury or damage ensure your camera is securely attached and to tighten all screws.
Also, spread your tripod legs as wide as possible for a solid foundation.
Insufficient leg spread may cause camera shake and the tripod to fall over.
- ⚠ Be careful running cable while providing driving power with USB cable.
Hooking cable may result tripod flip over and equipment falling over.
- ⊘ DO NOT use in the rain, dense fog, or in locations where the unit may get wet.
Electrocution or equipment failure may result if unit is handled or operated in wet conditions.
- ⊘ DO NOT apply any grease or oil to this product.
It may cause product failure.
If the movement of moving parts gets worse, please contact the dealer you purchased from or Slik Service Center.
- ⊘ DO NOT mix new and used batteries. It may cause fluid leaks or equipment failure.
- ⊘ DO NOT use the unit close to flames or leave in a hot car for a long time.
- ⊘ DO NOT use the unit for any other purpose than photography.

Maintenance

- ⚠ For cleaning the unit, use only a clean soft cloth with mild detergent.
Do not use organic solvents like paint thinner.
- ⚠ Remove batteries from the unit when not in use for a longer time.

Parts Descriptions

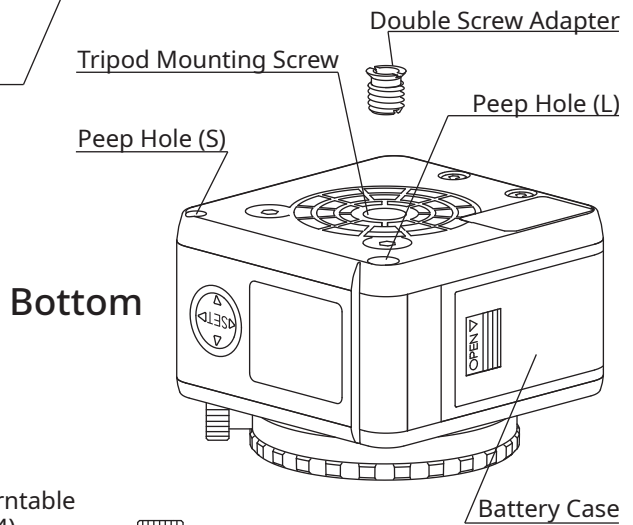
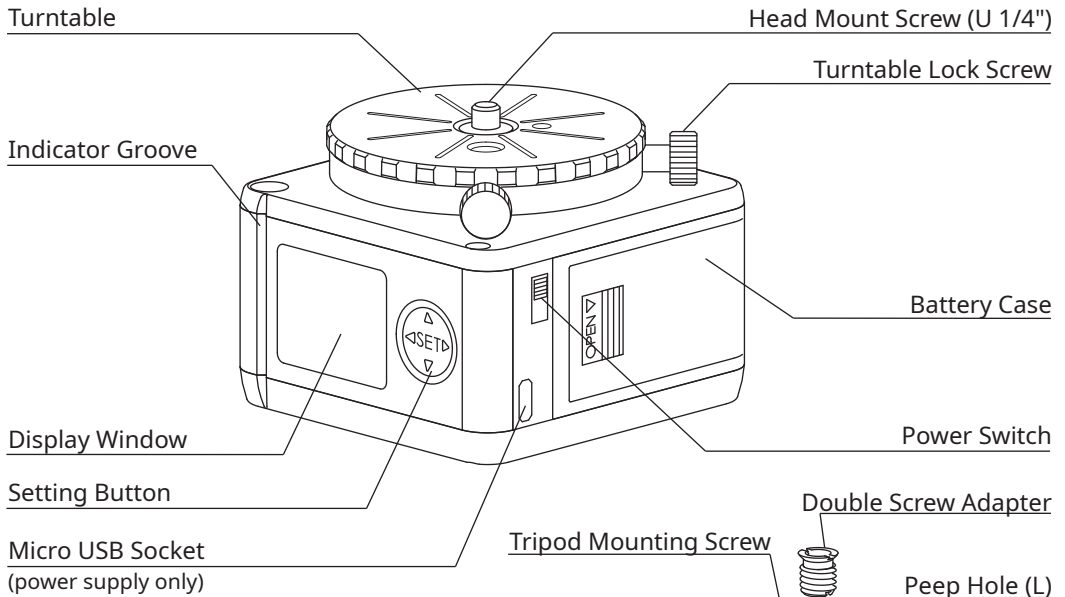

Turntable

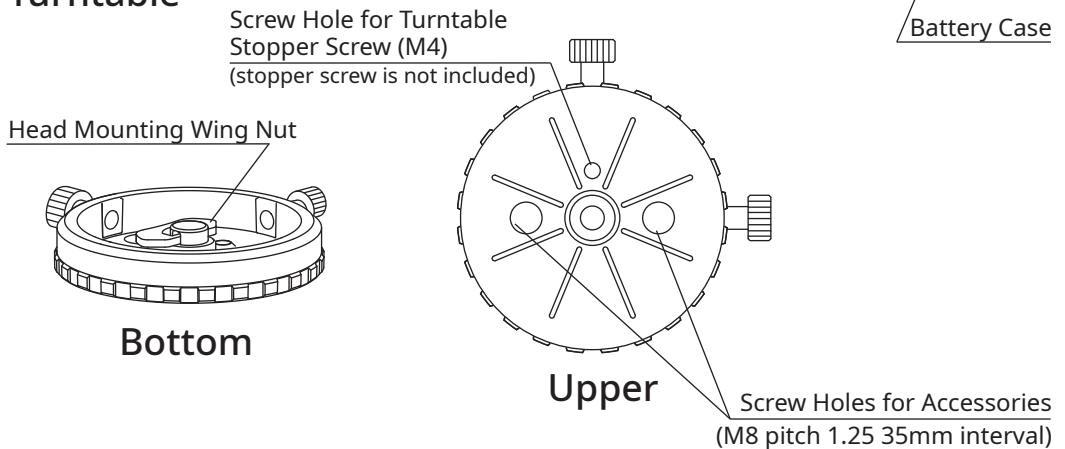

Before Use

■ About Test Shooting

It is important that you test the unit with your equipment prior to an important project.

Review the instruction manual thoroughly and ensure the unit is operating properly.

■ About Shooting Contents

Even if the results of using this product were not satisfactory, we are not compensate the recorded contents and expense related to the event.

■ About Mode

Refer page 7 to 11 for "Astronomical Photography Mode", Page 12 to 16 for "Time-Lapse Mode"

Necessary Equipment for Shooting

● ECH — 630

● Tripod

A medium or larger tripod is highly recommended for best results.

For connection with tripod, the unit accept either U 1/4 or U3/8" screw. To connect the unit with U3/8, remove Double Screw Adapter from the screw thread.

● Head 1 / Head 2 (for astronomical photography)

Head 1 is mounted on the turntable of the unit and set the composition of the shot Head 2 is placed in between tripod and the unit for astronomical photography.

It is used for adjusting polar alignment

● Camera / Lens / Recording Media & etc...

For Astronomical Photography

- The camera should have a Bulb (B) function or exposure times that meet your needs.

- Wide-angle to medium telephoto lenses are recommended. Super telephoto lenses are not suit for astronomical photography. For Time-Lapse Photography

- A camera must have an interval photography (Time-Lapse) mode, or controllable by a special shutter release cord.

● Power

Use four (4) AA Alkaline batteries (manganese and Ni-MH batteries can also be used), or mobile battery (with Micro USB cable)

It is recommended you keep batteries warm in low temperatures for increased shooting time.

Useful Items

- Cable shutter release
Pressing shutter button by finger may cause shaky image.
A release with the timer function is useful.
- Headlight or flashlight
Red light headlight or flashlight will reduce irritation to the eyes during astronomical photography.
Turn off light during exposure to avoid reflections.
- A planisphere and smartphone app is useful to confirm the direction of constellations and position of the stars.
- A protractor and compass
It is useful for polar axis setting.
(it is required during the shooting in the Southern Hemisphere)

Install batteries

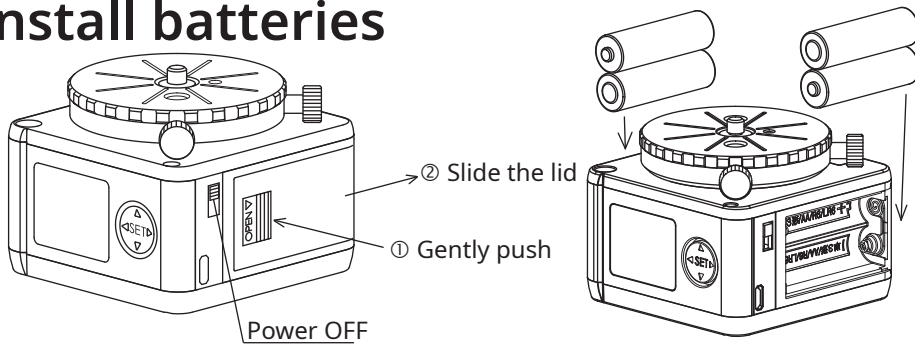

Use four (4) AA Alkaline batteries (manganese and Ni-MH batteries can also be used)

Make sure the power of the unit is OFF

- ① gently push the battery case lid
- ② slide the lid

Insert the batteries following the direction guide.

2 batteries will be placed on both sides of the unit.

⊗ DO NOT mix new and used battery.

Put battery case lid back.

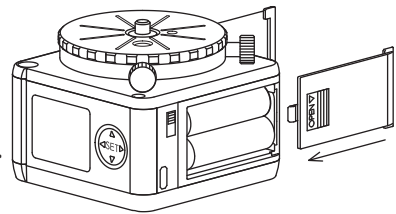

Powering the unit via USB cable

The unit can also be powered by external power supply such as mobile battery via Micro-USB connector. (more than 0.5A of current capacity)

The external power supply can be used while batteries are inserted into the unit.

The external power supply will take precedence over the batteries.

⊗ DO NOT use USB charger adapter.

It will damage internal circuit. Be careful where you place the battery unit and cable to avoid tripping and knocking over your tripod.

⚠ When connecting mobile battery to the unit via the USB port, we recommend that you install 4 pcs. of AA batteries to the unit.

The unit requires a very low stream of power during its setting process.

Some mobile batteries may not recognize this low stream and trigger their own internal "Auto-Off" function to conserve their batteries.

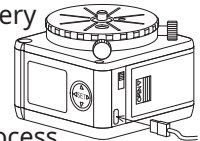

Brightness Setting for Display Light

On the setting screen upon powering up, press [▲] once to access the brightness setting. Brightness can be set from 1 to 20 when pressing [◀] [▶] buttons.

Press [SET] button to confirm the setting.

(The command will not execute without pressing [SET] button)



S	E	T	T	I	N	G											U	S	B
B	R	I	G	H	T	N	E	S	S										

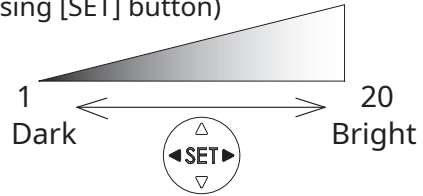

Illumination Time Setting

On the setting screen upon powering up, press [▲] twice to access the illumination time setting.

Illumination time can be selected when pressing [◀] [▶] buttons.

[ON] Light all the time

[15 s] Turn off after 15 seconds

[30 s] Turn off after 30 seconds

After selecting illumination time, press [SET] button twice.

(The command will not be executed without pressing [SET] button)

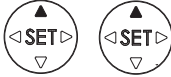

S	E	T	T	I	N	G													U	S	B	
L	I	G	H	T																		

Optional Equipment

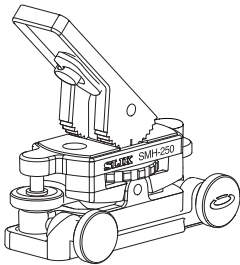

Micro Motion Head [MH-100]

Micro Motion Head [MH-100] is highly recommended for astronomical photography. As Micro Motion Head [MH-100] is designed for use with the equatorial mount, polar alignment can be performed easily.

Shoot Astronomy (from page 8 to 12)

★Install to the head

Option
Micro Motion Head
[MH-100]

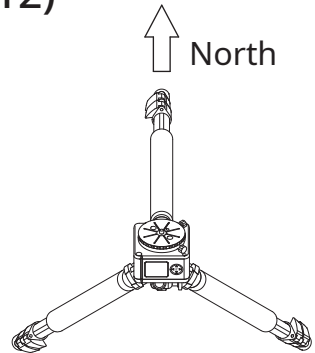
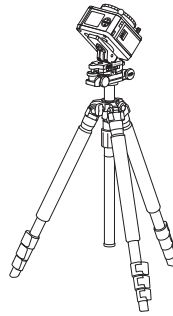
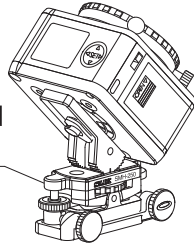

Install the unit to the head firmly.

When setting up the tripod, please make sure one tripod leg and the unit face north. Also, to prevent the tripod from falling over do not extend the tripod legs more than you need. When using a short tripod, please spread and extend each tripod leg as much as possible to prevent the tripod from falling.

★Find Polaris

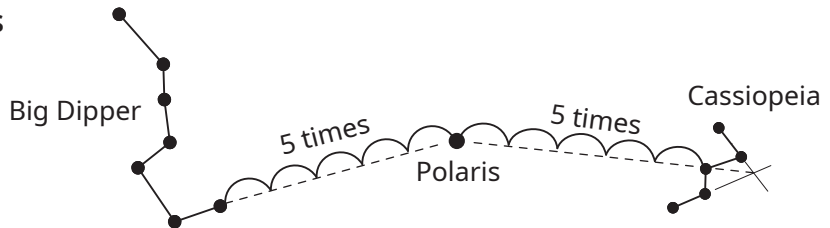

Polaris is a bright star that shines at north, and there are Big Dipper and Cassiopeia in the neighborhood.

To find the Polaris area;

- Locate two outer stars in the bowl of the Big Dipper.

Just draw a line between these two stars and extend it out about 5 times, and you eventually will reach the vicinity of Polaris.

There is a Polaris around five times the line connecting the star in the middle of the W and the intersection of the lines extended.

Depend on the season, time and place, one of constellation may not be observed.

★How to align Polar Axis (use peep holes)

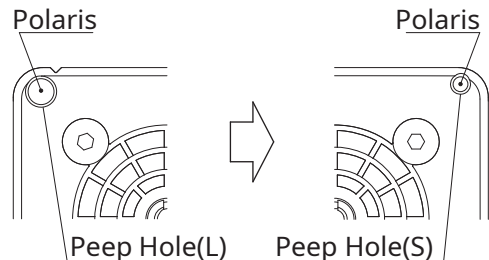
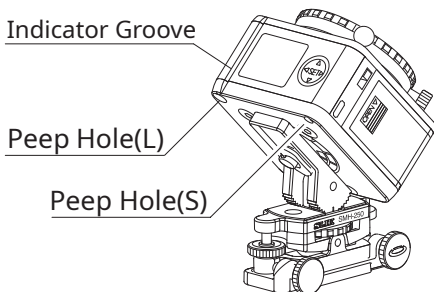

In the Northern hemisphere, you can use peep holes to match the polar axis.

Using indicator groove, point the head toward Polaris.

Move the head so that the Polaris will come in the peep hole (L).

Then, move the head to confirm Polaris is visible in the peep hole (S).

For smooth and easy operation, optional Micro Motion Head [MH-100] is ideal product.

★How to align Polar Axis (use compass and protractor)

Move the direction of the magnetic needle by about 7 degrees.

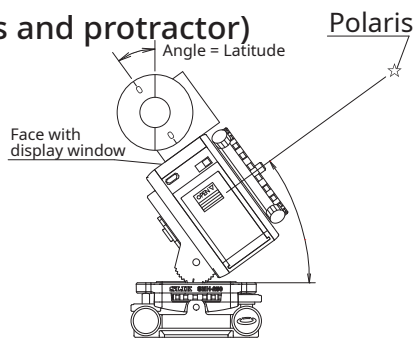
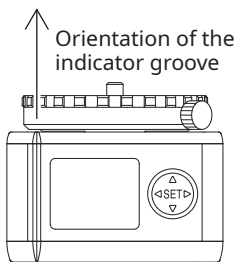
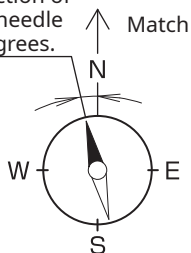

Polar axis can be easily matched with commercially available compass and protractor. When aligning direction, align the direction of N with the orientation of the indicator groove of the main body when the direction of the magnetic needle is shifted to the deviation angle. When adjusting the latitude, place a protractor on the surface where the display window is located, and adjust the angle so that the latitude is on the observation site. Latitude and delination of each place, see data sheet on page 18.

★Using in the Southern Hemisphere

When using the unit in the Southern Hemisphere, the compass and the protractor are necessary to adjust polar axis.

★Attaching the pan head

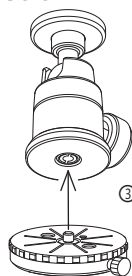
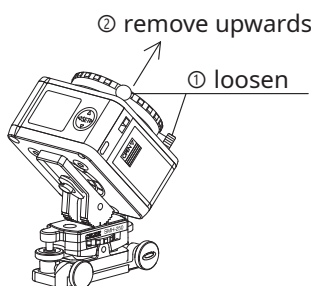

④ attach to the main body

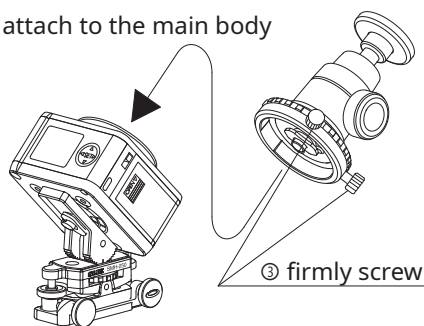

- ① loose the two fixing screws of the turntable
- ② remove turntable
- ③ turn a head mounting wing nut to securely install the pan head to the turntable.
- ④ put the turntable back to the main body and firmly fix the turntable with two fixing screws.

★Mounting Camera

Before mounting camera to the pan head, make sure two fixing screws are firmly tightened.

After mounting camera to the pan head, move the camera to the direction you want to shoot.

Setting the East side of the unit (right side of the display window) become slightly heavier will reduce the influence of gear rattle (backlash)

⚠Caution

Do not directly mount the camera to the turntable. It may damage the camera.

The center of gravity of the camera does not need to be the same as the position of the mounting screw. If one side of the camera is too heavy, it may rotate depending on the angle. Use a commercially available slide plate to correct the center of the gravity of the camera.

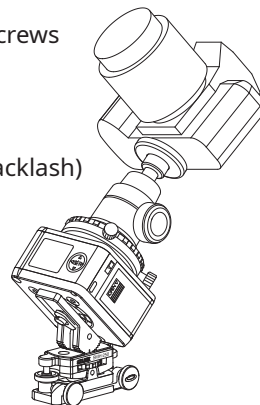

★Camera Setting

At first, set up the camera settings.
(shooting mode, shutter speed, aperture, ISO sensitivity and etc...)

◆ Shooting Mode, Shutter Speed

Set the camera to Bulb mode.

When the camera does not have a bulb mode, set shutter speed to more than 15 sec and try several test shots to find the optimum shutter speed.

◆ Aperture (F-number)

Set iris at wide open (smallest F-number) or close the aperture one step.

◆ ISO Sensitivity

Set ISO sensitivity to 400 or more.

Depending on the camera model, raising the sensitivity may result in poor image quality due to noise.

Try several test shots to find the optimum ISO sensitivity.

◆ Auto Focus

The auto focus function may not operate properly due to low light and lack of contrast. Set camera to Manual Focus and use viewfinder or live view mode for focus accuracy.

◆ Image Stabilizing Function

Turn off the image stabilizing function for best results.

For information about how to set up function and use the camera, please refer to the instruction manual for your camera.

★Setting Example for Starry Sky Shooting

◆ Lens: Focal Length 11 to 20mm F2.8

◆ Camera: Digital SLR Camera

◆ ISO Sensitivity: 1600

◆ Exposure Time: 60 to 120 sec.

※ Indication of Lens and Exposure Time in [STAR] (Star Tracking Mode)

Lens	15 mm	20 mm	24 mm	28 mm	35 mm	50 mm	70 mm	100 mm
Exposure Time	400 Sec.	300 Sec.	250 Sec.	214 Sec.	170 Sec.	120 Sec.	85 Sec.	60 Sec.

※ Above exposure time is a measure of the time taken to capture a star as a point image when capturing Polaris in the peep hole (S).

Above figures may change according to polar axis setting and shooting condition. Trial shooting is highly recommended to obtain optimum setting.

★Setting Example for Starscape Photography

◆ Lens: Focal Length 20mm F2

◆ ISO Sensitivity: 1600

◆ Exposure Time: 5 to 20 sec.

※ Indication of Lens and Exposure Time in [1/2] (Starscape Mode)

Lens	15 mm	20 mm	24 mm	28 mm	35 mm	50 mm	70 mm	100 mm
Exposure Time	18 Sec.	13 Sec.	11 Sec.	10 Sec.	8 Sec.	6 Sec.	4 Sec.	3 Sec.

※ Above exposure time is a measure of the time when the scenery far from the ground does not trail.

Above figures may change according to setting and shooting condition. Trial shooting is highly recommended to obtain optimum setting.

★Main Unit Setting

※ Display is an example

S	E	T	T	I	N	G											H	I	G	H	
M	O	D	E																		
	<	-	-	S	T	A	R	-	-	>											
S	T	A	R	N	O	R	T	H													

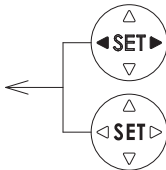

Press [◀] [▶] setting button and select [STAR] Star Tracking Mode

S	E	T	T	I	N	G												H	I	G	H
L	O	C	A	T	I	O	N														
	<	-	-	N	O	R	T	H	-	-	>										
S	T	A	R																		

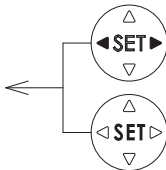

Press [SET] button
(press center of setting button)

Press [◀] [▶] button and select [NORTH] (Northern Hemisphere) or [SOUTH] (Southern Hemisphere).

S	E	T	T	I	N	G												H	I	G	H
F	I	N	I	S	H	?															
	<	-	-	Y	E	S	-	-	>												
S	T	A	R	N	O	R	T	H													

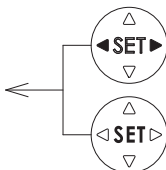

Press [SET] button to confirm the command

When preparation is finished, press the [SET] button to complete the setting.
To return to the previous setting, press [▼] of setting button.

Press [◀] [▶] of setting button to select [NO] and press the [SET] button will return to the first mode selection screen.

R	U	N	N	I	N	G												2	0	h	
E	Q	U	A	T	O	R	I	A	L												
S	T	A	R	N	O	R	T	H													
0	h	0	m	0	s																

Screen display will be toggled to operation display.

※ Setting change is not possible when the unit is in operation.

※ As described in the Star Tracking Mode, the setting items are the same in the SUN Tracking, the Moon Tracking and the Starscape Mode.

※ Short-cut

The unit stores the last setting when the power is turned off.

To use the same settings as last time, press [▼] setting button then turn on the power switch, it will short-cut to the final confirmation screen.

★About Running Screen

Current Status →	R	U	N	N	I	N	G											2	0	h	
Running Mode →	E	Q	U	A	T	O	R	I	A	L											
Setting →	S	T	A	R	N	O	R	T	H												
Elapsed Time →	0	h	0	m	0	s															

← Operation Time/
External Power Supply(USB)

※ Operation time is set assuming the use of alkaline batteries.

With manganese batteries or Ni-MH rechargeable batteries, the correct operation time is not displayed.

Also, even alkaline batteries, there are individual differences depending on the battery type and environmental conditions, so please use the display time as a reference.

※ The display of the operation mode selection will be [EQUATORIAL] except for the Time-Lapse Mode.

※ The backlight turns off automatically.

To turn the backlight on again, press setting button.

→ to change backlight time, refer to the page 7 for instructions

★Turn Off the Power

To turn off the power of the unit, turn off the power switch.

Also, to change the setting while the unit is in operation, turn off the power.

Then, turn on the power switch and change setting.

Time-Lapse Shooting (from Page 13 to 17)

◎Mounting on the Tripod

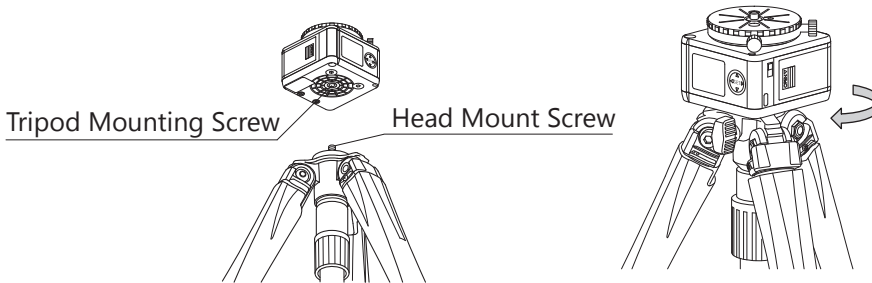

Mount the unit firmly to the tripod.

To mount the unit to the tripod with U3/8 mounting screw, remove the double screw adapter out from the screw hole with a coin, screwdriver, etc.

To prevent the tripod from falling over, do not extend tripod legs more than necessary.

To adjust the center of gravity of the camera near to the center of the turntable, see commercially available slide plate.

◎Attaching the pan head

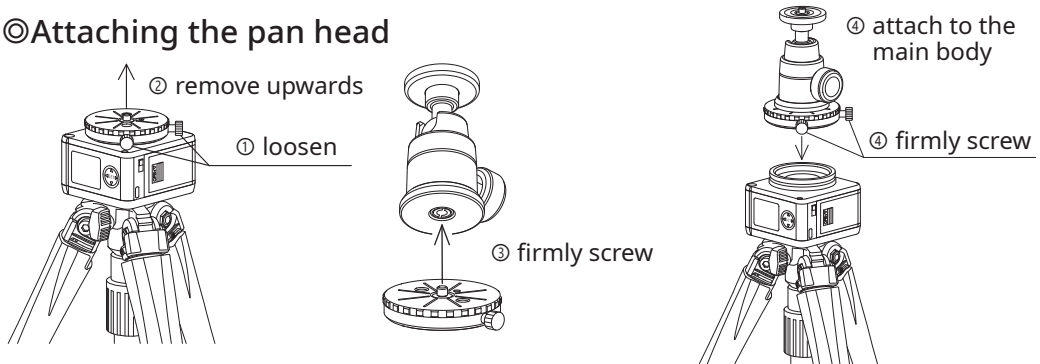

① loosen the two fixing screws of the turntable

② remove turntable

③ turn the head mounting wing nut to securely install the pan head to the turntable.

④ put the turntable back to the main body and firmly fix the turntable with two fixing screws.

◎Mounting Camera

Before mounting camera to the pan head, make sure two fixing screws are firmly tightened. After mounting the camera to the pan head, move the camera to the direction you want to shoot.

⚠Caution

Do not directly mount the camera to the turntable.

It may damage the camera.

The center of gravity of the camera does not need to be the same as the position of the mounting screw.

If one side of the camera is too heavy, it may rotate depending on the angle.

Use a commercially available slide plate to correct the center of gravity of the camera.

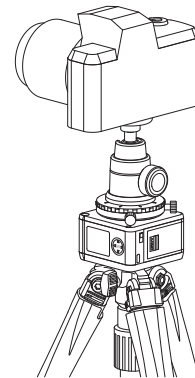

◎About Time-Lapse Mode

This product can rotate at a constant speed for time-lapse shooting.

Several settings can be done with the unit will be explained below;

ONE WAY.....Rotates in the selected direction
(choose from continuous rotation or stop at a set angle)

SWING.....Rotates in the selected direction, then
rotates in the opposite direction
(continuous operation only)

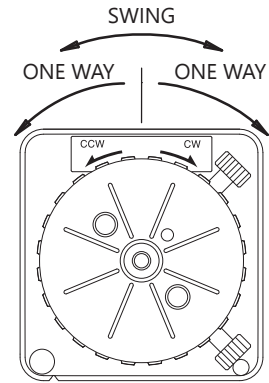

In SWING mode, swing motion is performed at a set angle with the rotation start position at the center.
(ex. If SWING is set to 30 degrees the table turns 30 degrees in the specified direction.
Then rotate 30 degrees in opposite direction. It repeats its operation alternatively.)

Also, the direction of rotation, the rotation angle and the rotation speed can be set.

Direction of RotationClockwise (CW), Counterclockwise (CCW)

Rotation Speedfrom 48 hours per turn to 15 minutes per turn ((9 types)

Rotation Anglefrom 5 to 360° (5 increments), ENDLESS (only ONE WAY)

ENDLESS will continuously rotate in one direction.

※ Time-Lapse Rotation Speed Table

Display (/1R)	48 h	24 h	12 h	6 h	3 h	1.5 h	1 h	30 m	15 m
One Hour Rotation Angle	7.5°	15°	30°	60°	120°	240°	360°	720°	1440°

◎About Time-Lapse Shooting (Interval Shooting)

Using the camera's interval mode and a shutter release cable is highly recommended for best results.

Pressing the shutter button by finger will cause camera shake and create blurred images.

Use a commercially available release with time-lapse (interval shooting) function when your camera does not have a time-lapse function

※ Approximate Minimum Shutter Speed

Display (/1R)	48 h	24 h	12 h	6 h	3 h	1.5 h	1 h	30 m	15 m	
Lens	15 mm	18	9	4	2	1	1/2	1/2	1/5	1/10
	20 mm	13	7	3	2	1	1/2	1/3	1/8	1/15
	24 mm	11	6	3	1.5	1/2	1/3	1/4	1/8	1/20
	28 mm	10	5	2	1	1/2	1/3	1/5	1/10	1/20
	35 mm	8	4	2	1	1/2	1/4	1/6	1/12	1/20
	50 mm	6	3	1.5	1/2	1/3	1/5	1/8	1/20	1/35
	70 mm	4	2	1	1/2	1/4	1/10	1/12	1/25	1/50
	100 mm	3	1.5	0.5	1/3	1/5	1/10	1/20	1/50	1/70

※ Setting the shutter speed higher than the suggested number will reduce blur caused by rotation and produce reduced star trails.

The setting of the shutter speed may vary depending on the location and shooting conditions, so test shots are highly recommended to find the optimum setting.

◎About Setting Screen Display of Time-Lapse Mode

The display contents of the setting screen for the last time-lapse mode differ from the one of astronomical photography mode.

Set the unit referring following figure and the [◎ Main Unit Setting] column.

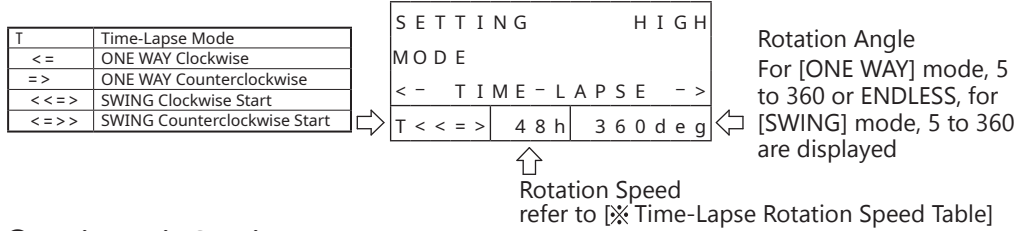

◎Main Unit Setting

※ Display is an example

SETTING		HIGH	
MODE			
< - TIME - LAPSE - >			
T < < = >	4 8 h	3 6 0	d e g

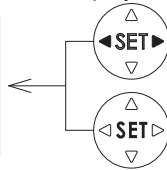

Press [◀] [▶] setting button and select [TIME-LAPSE] mode

Press [SET] button to confirm the command (press center of setting button)

SETTING		HIGH	
TURN MODE			
< - - ONE WAY - - >			
T			

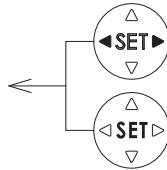

Press [◀] [▶] setting button and select [ONE WAY] or [SWING] mode

Press [SET] button to confirm the command

SETTING		HIGH	
START DIRECTION			
< - - CW <= - - >			
T <=			

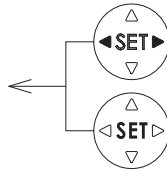

Press [◀] [▶] setting button and select direction of rotation [CW](clockwise) or [CCW](counterclockwise)

Press [SET] button to confirm the command

SETTING		HIGH	
SPEED			
< - - 4 8 h / 1 R - - >			
T <=			

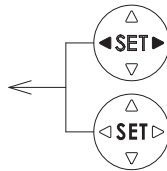

Press [◀] [▶] setting button and select rotation speed.
Refer to Time-Lapse Rotation Speed on page 14

Press [SET] button to confirm the command

SETTING		HIGH	
ROTATION ANGLE			
< - - 3 6 0 d e g - - >			
T <=	4 8 h		

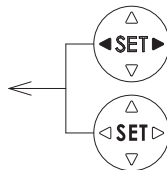

Press [◀] [▶] setting button and select rotation angle. For [SWING] mode, the rotation angle from 5 to 360° (5° increments) for [ONE WAY] mode, the rotation angle for 5 to 360° (5° increments) or [ENDLESS] can be selected.

Press [SET] button to confirm the command

↓

S	E	T	T	I	N	G										H	I	G	H
F	I	N	I	S	H	?													
	<	-	-			Y	E	S		-	-	>							
T	<	<	=	>		4	8	h		3	6	0	d	e	e	g			



After preparation is completed, press [SET] button to complete the settings.
 To return to the previous setting, press [▼] of setting button.
 Press [◀] [▶] of setting button to select [NO] and press the [SET] button will return to the first mode selection screen.

↓

R	U	N	N	I	N	G													2	0	h	
T	I	M	E	L	A	P	S	E		O	N	E	W	A	Y							
4	8	h	/	1	R		<	=		3	6	0	d	e	e	g						
0	h	0	m	0	s																	

Screen display will be toggled to operation display.
 ※ setting change is not possible while the unit is in operation.

※ Short-cut

The unit stores the last setting when the power is turned off.
 To use the same setting as last time, press [▼] setting button while turning on the power switch, it will short-cut to the final confirmation screen.

◎About Running Screen

Current Status →	R	U	N	N	I	N	G														2	0	h	← Operation Time/ External Power Supply (USB)	
Running Mode →	T	I	M	E	L	A	P	S	E		O	N	E	W	A	Y									
Setting →	4	8	h	/	1	R		<	=		3	6	0	d	e	e	g								
Elapsed Time →	0	h	0	m	0	s																			

- ※ Operation time is set assuming use of alkaline batteries.
 With manganese batteries, Ni-MH rechargeable batteries, the correct operation time is not displayed. Also, even alkaline batteries, there are individual difference depend on the type and condition, so please use the display time as a reference
- ※ For the operation mode display, [ONE WAY] or [SWING] is displayed to the right of [TIMELAPSE]
- ※ The backlight turns off automatically.
 To turn the backlight on again, press setting button
 → to change backlight time, refer to the page 7 and change the setting.

◎Turn Off the Power

To turn off the power of the unit, turn off the power switch.
 Also, to change the setting while the unit is in operation, turn off the power.
 Then, turn on the power switch and change setting.

UKCA Declaration of Conformity

UKCA Bresser UK Ltd. has issued a „Declaration of Conformity“ in accordance with applicable guidelines and corresponding standards. The full text of the UKCA declaration of conformity is available at the following internet address: www.bresser.de/download/4964130/UKCA/4964130_UKCA.pdf

Bresser UK Ltd. • Suite 3G, Eden House, Enterprise Way, Edenbridge, Kent TN8 6Hf, Great Britain

Data Sheet

A Table for Latitude and Deviation Angle for Major Cities of the World

CITY	LATITUDE	MAGNETIC DECLINATION	CITY	LATITUDE	MAGNETIC DECLINATION
Abidjan	5.336° N	4.72° W	London	51.509° N	0.46° W
Addis Ababa	9.023° N	2.28° E	Los Angeles	34.052° N	12.05° E
Alexandria	31.228° N	4.40° E	Luanda	8.814° S	3.5° W
Amman	31.949° N	4.67° E	Madrid	40.422° N	0.76° W
Athens	37.974° N	4.43° E	Manila	14.601° N	2.13° W
Auckland	36.904° S	19.75° E	Marseille	43.291° N	1.58° E
Baghdad	33.332° N	4.61° E	Melbourne	37.81° S	11.62° E
Bangkok	13.731° N	0.57° W	Mexico City	19.411° N	4.68° E
Barcelona	41.385° N	0.81° E	Milan	45.471° N	2.48° E
Beijing	39.904° N	6.84° W	Monaco	43.739° N	2.06° E
Beograd	44.802° N	4.67° E	Montevideo	34.894° S	10.64° W
Berlin	52.524° N	3.75° E	Moscow	55.746° N	11.04° E
Bishkek	42.87° N	5.37° E	Munich	48.14° N	3.11° E
Bissau	11.864° N	7.25° W	N' Djamena	12.105° N	1.16° E
Bogata	4.61° N	7.26° W	New Delhi	28.638° N	1.2° E
Brazzaville	4.281° S	1.39° W	New York	40.714° N	12.92° W
Brussels	50.837° N	1.05° E	Nairobi	1.274° S	0.58° E
Bucharest	44.43° N	5.56° E	Ottawa	45.412° N	13.29° W
Budapest	47.491° N	4.7° E	Panama	8.994° N	4.41° W
Buenos Aires	34.612° S	8.91° W	Paris	48.853° N	0.57° E
Cairo	30.065° N	4.37° E	Perth	31.933° S	1.71° W
Calcutta	22.544° N	0.24° W	Phnom Penh	11.559° N	0.5° W
Cape Town	33.925° S	25.21° W	Plymouth	50.379° N	1.76° W
Caracas	10.491° N	12.31° W	Prague	50.079° N	3.92° E
Casablanca	33.605° N	1.85° W	Rio de Janeiro	22.909° S	22.77° W
Chicago	41.85° N	3.9° W	Riyadh	24.640° N	2.99° E
Christchurch	43.524° S	23.89° E	Rome	41.899° N	3.04° E
Colombo	6.927° N	2.13° W	Saint Petersburg	59.952° N	10.77° E
Copenhagen	55.693° N	3.66° E	San Jose (CRI)	9.927° N	1.74° W
Dakar	14.687° N	7.37° W	Sao Paulo	23.581° S	21.32° W
Damascus	33.519° N	4.86° E	Sarajevo	43.856° N	4.23° E
Dhaka	23.71° N	0.25° W	Seattle	47.606° N	15.76° E
Djibuti	11.589° N	1.91° E	Seoul	37.532° N	8.38° W
Dubai	25.282° N	2.48° E	Shanghai	31.248° N	5.93° W
Dublin	53.342° N	3.05° W	Singapore	1.299° N	0.21° E
Dushanbe	38.565° N	4.44° E	Skopji	42.004° N	4.54° E
Guatemala City	14.625° N	1.1° E	Sofia	42.711° N	4.9° E
Hanoi	21.024° N	1.46° W	Stockholm	59.287° N	6.11° E
Havana	23.117° N	4.91° W	Sydney	33.892° S	12.59° E
Helsinki	60.161° N	8.86° E	Taipei	25.035° N	4.43° W
Ho Chi Minh	10.759° N	0.47° W	Tbilisi	41.71° N	6.64° E
Hong Kong	22.278° N	2.84° W	Teheran	35.696° N	4.73° E
Istanbul	41.066° N	5.44° W	Tokyo	35.681° N	7.42° W
Jakarta	6.212° S	0.65° E	Toshkent	41.305° N	5.4° E
Jerusalem	31.774° N	4.64° E	Tripoli	32.876° N	2.63° E
Kabul	34.528° N	3.13° E	Tunis	36.819° N	2.39° E
Kiev	50.454° N	7.58° E	Ulan Bator	47.921° N	4.64° W
Kinshasa	4.321° S	1.39° W	Vancouver	49.243° N	16.29° E
Kuala Lumpur	3.15° N	0.04° W	Vladivostok	43.125° N	10.34° W
Kuwait	29.329° N	3.59° E	Warsaw	52.245° N	5.83° E
La Paz	16.499° S	7.93° W	Washington	38.895° N	10.87° W
Lima	12.093° S	1.81° W	Wien	48.202° N	4.23° E
Lisbon	38.727° N	2.4° W	Yangon	16.784° N	0.67° W

✂ For regional information other than above, please refer to the topographic map or the Geographical Survey Institute Homepage.

FAQ

Symptom	Cause	Solution
Batteries do not get in ... when using batteries	Battery exhausted	Replace with new battery
	Battery is inserted upside down	Check the polarity (+ and -) of the battery and insert batteries again in right direction
	Lack of remaining battery	Charge external power supply
... when using external power supply	Cable is not properly connected	Check the direction and rattling of the cable and connect it correctly
Want to charge via USB		Cannot be charged via USB cable
Want to set up the unit from PC via USB		Set-up the from PC via USB is not supported
Backlight goes off	Backlight illumination time is too short	Backlight illumination time can be set at „15 sec.“, „30 sec.“ or „light all the time“. For setting details see page 7
Backlight brightness is too high or too dark	Brightness is not set up correctly	Backlight brightness can be selected in 20 steps. For setting details see page 7
Want to use the unit with a tripod with U3/8 screw		Remove the adapter from the tripod mount on the bottom of the unit
Pressing the down button changes the mode arbitrarily		Pressing the down button on the mode setting screen to switch to the previously set mode. Pressing the up button will bring screen to mode selection screen.
I do not understand what is being displayed		For astronomical photography mode, see operation screen on page 12, for time-lapse mode, see operation screen on page 17
Setting can not be changed after operation		Setting change is not possible while the unit is in operation. Turn off the power and set it again.
Stars are blurred	Correct mode is not selected	The programmed contents differ in each mode. Select the mode suitable for the purpose
	Hemisphere is not correctly selected	Select the correct mode according to observation site
	Misaligned polar axis	See page 8 and set the polar axis again
	Exposure time is too long	Change ISO sensitivity and exposure time setting.
	There is not solid connection to the tripod, the pan head or the camera	Tighten the screws and check additional connection points for any play
There is a play in the main body axis		It is not abnormal as some play is necessary for the smooth movement of the gears

Product Specification

Model	PM-100
Dimension	D: 84mm x W: 86mm x H: 65mm (exclude protrusions)
Weight	630g (without batteries)
Max. Load Capacity	at Astronomical Mode: 5kg (2kg at C.O.G. height of 10cm from the turntable / less than 20 kg • cm of moment load)
	at Time-Lapse Mode When the turntable and the ground are close to parallel: 5kg When the turntable and the ground are close to perpendicular: 2kg (2kg C.O.G. height of 10cm from the turntable / less than 20kg • cm of moment load)
Head Mounting Screw	U 1/4
Tripod Mounting Screw	U 1/4 • U3/8 (remove double screw adapter)
Polar Axis Diameter	17mm
Worm Wheel	made of duralumin outer diameter: 51mm gear teeth: 100
Worm Screw	made of brass outer diameter: 10mm
Reduction Ratio	Inner: 1/91 Outer: 1/2.5 Worm Wheel: 1/100
Motor	compact bipolar stepping motor
Driver	constant current driver
Drive Frequency	[STAR]mode: at sidereal time [MOON] mode: moon average
Operating Temperature	-10°C ~ 40°C (No condensation)
Power	4AA alkaline batteries (AA manganese or Ni-MH rechargeable batteries can also be used) DC5V (Micro-USB)
Battery Duration	about 20 hours (with alkaline batteries) (at [STAR] mode, 20°C, no backlight)
Power Consumption	about 100mA (at [STAR] mode, no backlight)

Spare parts will be held for about five (5) years from discontinuation of production.
Product repair service is available during the period.
Errors and technical changes reserved.

Please contact the service centre first for any questions regarding the product or claims, preferably by e-mail.

* Number charged at local rates in the UK (the amount you will be charged per phone call will depend on the tariff of your phone provider); calls from abroad will involve higher costs.

e-mail: service@bresseruk.com
Telephone*: +44 1342 837 098
www.bresser.de
Bresser UK Ltd
Suite G3, Eden House
Enterprise Way
Edenbridge, Kent TN8 6HF