



Vixen®



ED80Sf ED100Sf

REFLECTORS

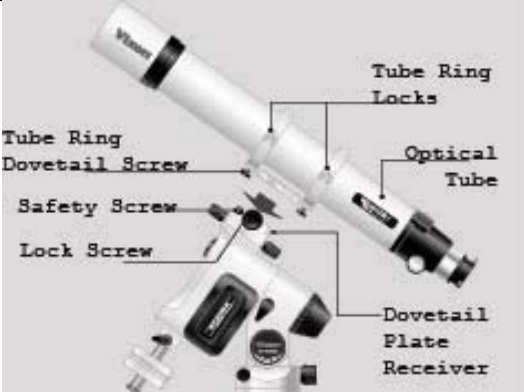

Vixen Optics a Division of MrStarGuy, Inc. www.vixenoptics.com

PREFACE	
Thank you very much for your purchase of a Vixen astronomical telescope	
This manual applies to the ED80Sf and ED100Sf telescopes. You may occasionally find descriptions in the text not relevant to your particular model. Read the instructions for your mount along with this manual if you purchased the telescope as a complete package.	
WARNING!	
Never look directly at the sun with the telescope or its finder or guide scope. Permanent and irreversible eye damage may result.	
CAUTION	
Do not leave the optical tube uncapped in the daytime. Sunlight passing through the telescope or finder scope may cause a fire.	
Do not use the product while moving or walking, injuries could result from a collision with objects or from stumbling or falling.	
Keep small caps, plastic bags, or plastic packing materials away from children. These may cause a danger of swallowing or suffocation.	
Do not use the product in a wet environment and do not handle with wet hands.	
HANDLING AND STORAGE	
Do not leave the product inside a car in bright sunshine or in other hot places. Keep any strong heat sources away from the product.	
When cleaning, do not use solvents such as paint thinner or similar products.	
Do not expose the product to rain, water, dirt or sand.	
Avoid touching any lens or mirror surfaces directly with your hands. In case a lens or mirror becomes dirty with fingerprints or general smears, gently wipe it using a commercially available lens cleaner and a lens cleaning paper or cloth, or consult your local Vixen dealer.	
Blow off dust on lenses using a commercially available blower brush. Do not use compressed air.	
For storage, keep the product in a dry place and do not expose to direct sunlight.	
SETTING UP THE TELESCOPE- Refer to your mount instructions along with this manual.	
ATTACHING THE TELESCOPE TO THE MOUNT (GP2 mount and A80Mf optical tube shown here)	
Loosen both the dovetail-plate lock screw and safety screw until the tips of these screws no longer extended into the inner part of the dovetail block.	Slide the dovetail mounted scope into the dovetail mounting block as shown in the figure. Tighten the dovetail lock screw (centered on the notch) onto the dovetail tube plate until snug.
	
First tighten the dovetail lock screw, and then tighten the small chrome safety screw onto the dovetail mounting block until snug.	

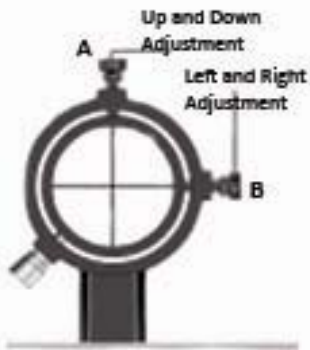
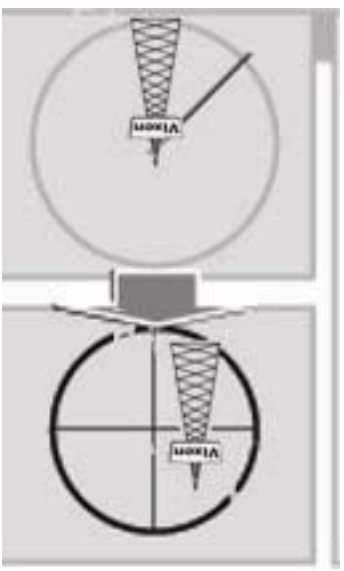
ATTACHING THE FINDER SCOPE	
<p>(1) Back out the adjustment screw on the finder bracket to allow passage of the finder scope. (Make sure the adjustment screws do not fall off the bracket.)</p>	
<p>(3) Pull up the fixed stud on the bracket ring and pull it so that the finder tube slides into the bracket ring from its eyepiece end. Release the fixed stud so the wide groove on the finder tube is underneath the stud.</p>	
<p>(2) Slide the rubber O-ring onto the eyepiece end of the finder. There are two grooves on the finder tube. Position the O-ring on the narrow groove at the middle of the finder tube.</p>	
<p>(4) Tighten the two adjustment screws so that the finder scope is aligned as shown in the figure.</p>	
<p>Loosen the finder bracket lock thumbscrew on the telescope.</p>	<p>Attach the finder bracket as shown in the figure, tighten the finder bracket lock thumbscrew securely.</p>
ALIGNING THE FINDER SCOPE – Be sure to align the finder scope before you begin observing.	
<p>(1) Choose a conspicuous target in the distance and place the target in the center of the field of view of the telescope. (In the illustration, a distant tower is brought into the center of the field of view of the telescope.)</p> <p>(2) Next, look through the finder scope. You should probably find the same target somewhere within the finder's field of view. (The finder scope has crosshairs.)</p> <p>(3) Align the optical axis (field of view) of the finder scope with the optical axis (field of view) of the telescope. Adjust the finder scope by loosening or tightening the adjustment screws A and B (In Figure #4 Above) until the target is in the same position, in the center of the crosshairs. (In the illustration, the top of the tower is in the center of the crosshairs.)</p>	

ACCESSORY CHART – You may need an eyepiece as sold separately.

Visual Configuration

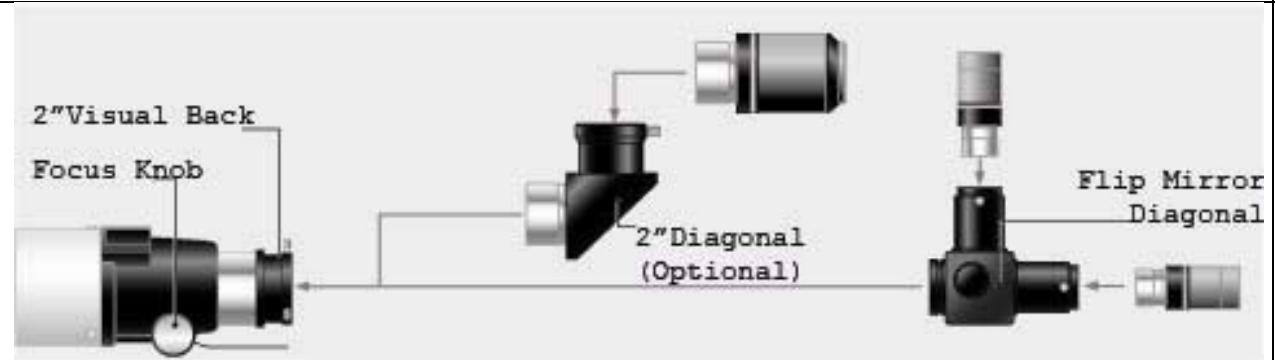

Example: Calculating the eyepiece magnification of a telescope with 1035mm focal length.

Eyepiece	Focal length of telescope	Focal length of eyepiece	Magnification
PL20mm	600 mm	20mm	30x
PL 5mm	600 mm	5mm	120x

PHOTOGRAPHIC CONFIGURATION

Photographic Configuration	Prime Focus Photography	
	Eyepiece Projection Photography	
	Afocal Imaging Photography	

Please check if your camera has a filter thread which can fit our DG-DX ring.

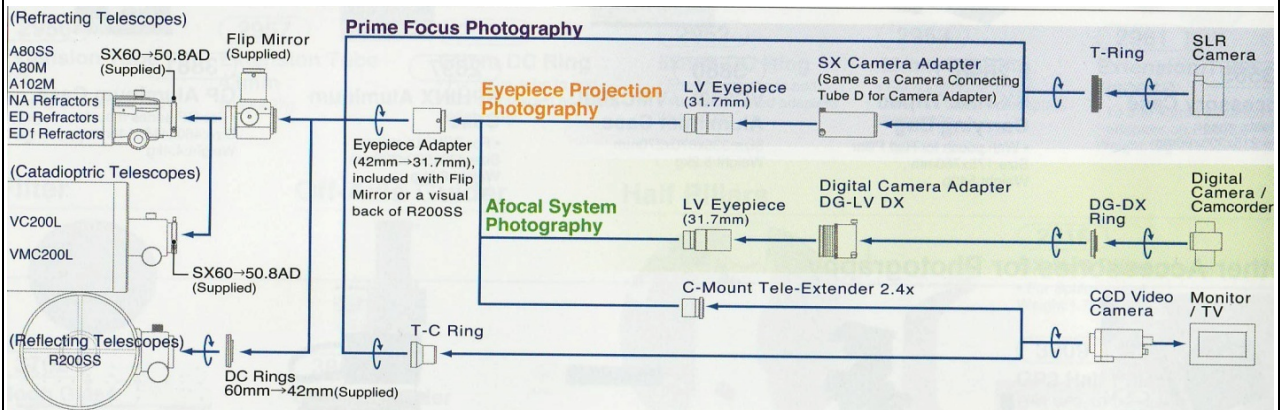

SPECIFICATIONS			
Specifications	ED80Sf		ED100Sf
Item #	3228		3229
Optical Design	ED APOchromatic Refractor		
Effective Aperture	80mm		100mm
Focal Length	600mm (f/7.5)		900mm (f/9.0)
Resolving Power	1.45 arc.; 11.3		1.16 arc sec; 11.8
Light Gathering Power	131x		204x
Tube Diameter, Length & Weight	100mmx570mm; 3.4 kg		100mm x 880mm; 3.7kg
Finderscope	9x50mm		9x50mm
Threads	60mm, 42mm threaded for T-ring/50.8mm, 31.7mm push-fit for T ring/31.7mm push-fit		
Accessories	Flip Mirror, Aluminum Carry Case, Mount Rings, Dovetail Plate		
Photography			
Total Weight	8.9kg 19.6 lbs total weight		11.5 kg 25.3 lbs total w/case
	7.5 lbs optical tube		8.2 lbs optical tube
ABOUT THE CRAYFORD FOCUSER			
<p>Both the ED80Sf and ED100Sf telescopes have the Crayford focuser which uses friction for the focusing mechanism. Follow these instructions for its use.</p> <p>Tighten the tension adjustment screw if the drawtube is loose.</p> <p>Even with the tension knob fully tightened , it is possible , though not recommended, to rotate the focus knobs.</p> <p>Never apply lubricant to the focuser.</p>			